

LOC		DIST		ZONE		LTR		REVISIONS		DATE	APPD
AF	50	P	F					AD	ADDED -6 PER 0G3A-0271-01	17MAY01	MF-KR

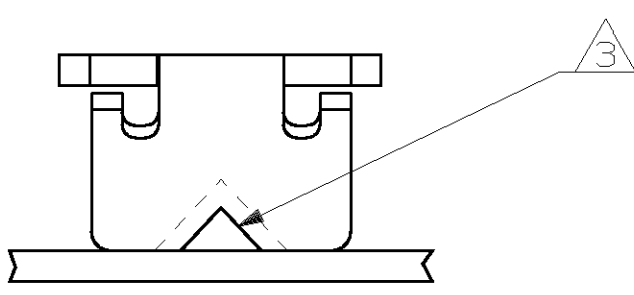

- 1 CONTINUOUS STRIP ON REELS WITH TERMINALS LOCATED ON 5.59±0.08 [.220±.003] CENTERS.
- 2 SLOT ACCEPTS 0.64-0.81mm [#22-#20] AWG COPPER MAGNET WIRE. A SINGLE WIRE ONLY.
- 3 POKE-IN ACCEPTS A 0.81-1.02mm² [#20-#18] AWG SOLID OR FUSED STRANDED LEAD WIRE.
- 4 0.002032 [.000080] MIN TIN.
- 5 VARNISH RESIST OVER 0.002032 [.000080] MIN TIN.
- 6 SPECIAL REEL QUANTITY FOR AMP SPAIN PRODUCTION ONLY.
- 7 PRELIMINARY - NOT FOR PRODUCTION.

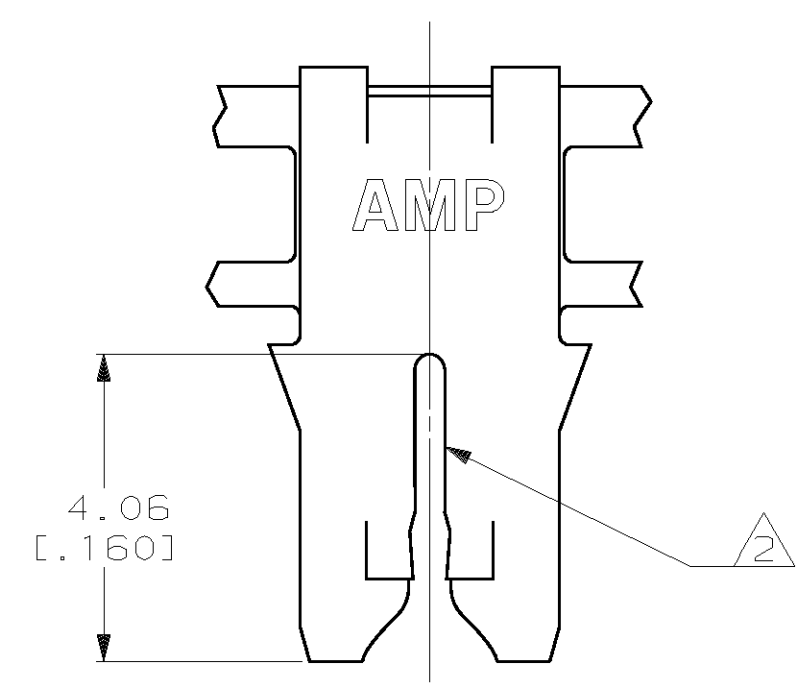
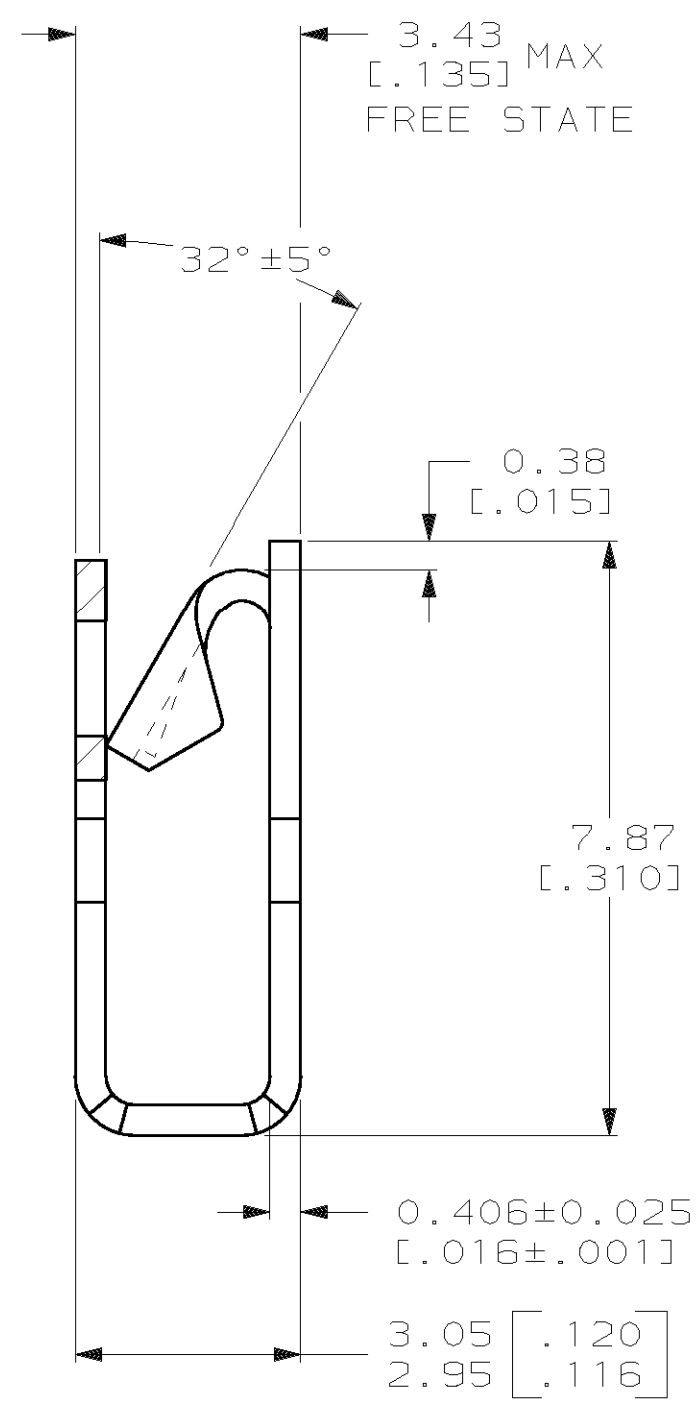
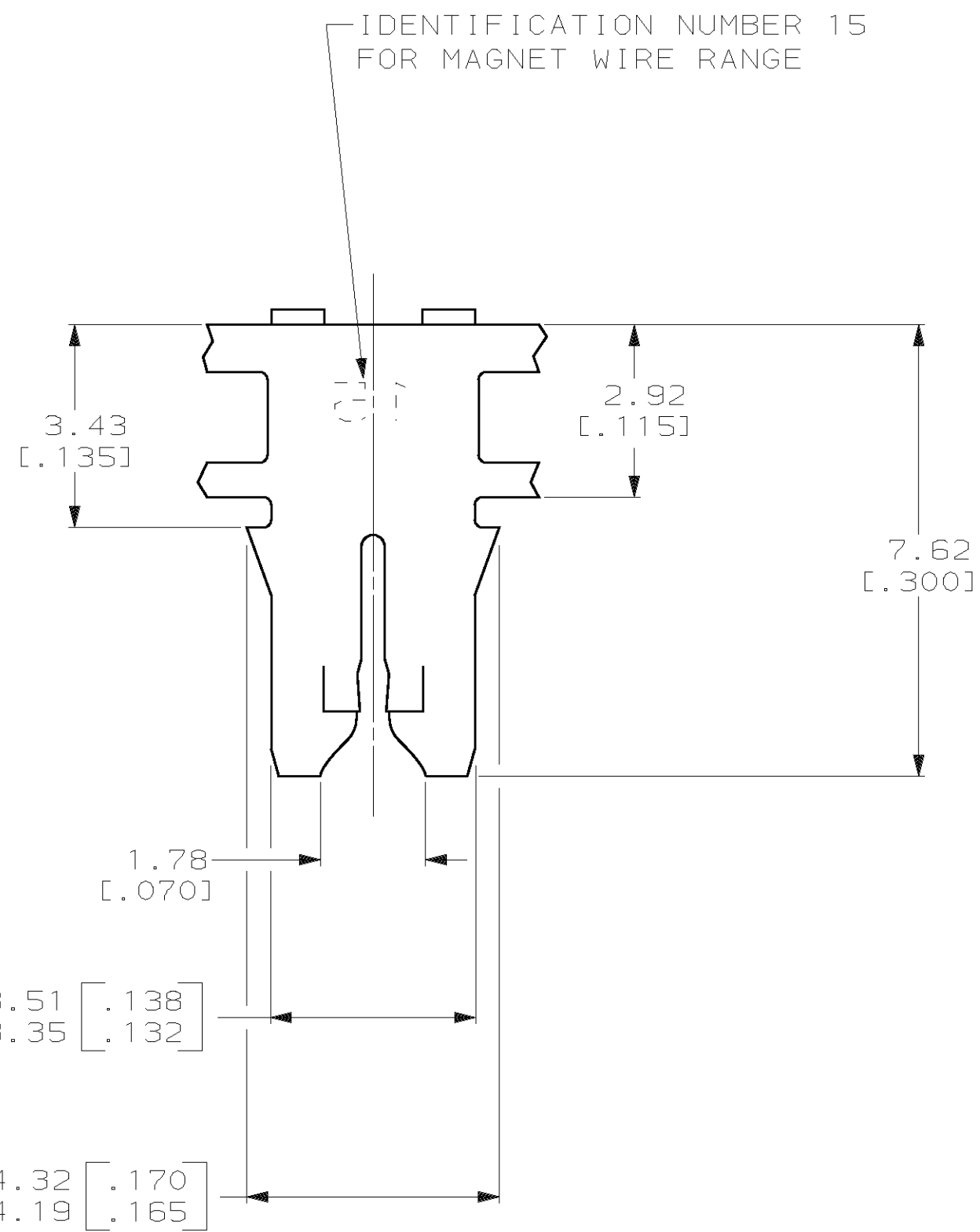

REVERSE	WELD	CARDBOARD REEL	4M BRASS	4	7	62420-6
STANDARD	SPLICE FREE	PLASTIC REEL	4M BRASS	4	7	62420-5
STANDARD	WELD	CARDBOARD REEL	H04 PHOSPHOR BRONZE	4		62420-4
STANDARD	WELD	CARDBOARD REEL	4M BRASS	4	6	62420-3
STANDARD	WELD	CARDBOARD REEL	4M BRASS	5		62420-2
STANDARD	WELD	CARDBOARD REEL	4M BRASS	4		62420-1
REELING DIRECTION	SPLICE	REELING MATERIAL	MATERIAL	FINISH		PART NO

DO NOT SCALE PRINT. UNLESS SPECIFIED DIMENSIONS IN mm [INCHES] TOLERANCES ON : 2 PLC DEC ± 0.25 [.010] 3 PLC DEC ± - ANGLES ± -	DR 5/19/92 MICHAEL S. FEHER	AMP Incorporated Harrisburg, PA 17105-3608
	CHK 5/20/92 JEFF R. RUTH	
MATERIAL	APPD 5/21/92 NELSON E. NEFF	NAME
SEE TABLE	APPD 5/21/92 TERRY L. SHUTTER	TERMINAL, POKE-IN, 300 SERIES MAG-MATE™
FINISH	PRODUCT SPEC 108-2012	SIZE
SEE TABLE	APPLICATION SPEC 114-2046	CAGE CODE 00779
	WEIGHT -	DRAWING NO 62420
		SCALE 10:1
		SHEET 1 OF 1